



miniweigher plus



This small and compact mini crane weigher scale will suit most lifting applications. Available in capacities from 100kg to 5t. Worldwide, it's our most popular product and has been manufactured since 1987. The MiniWeigher Plus crane scale offers robust construction, high accuracy, compact size and extreme portability.

Utilised by utility companies on every continent, the MiniWeigher Plus crane scale is quite often mounted between a winch and a tripod, allowing the load monitoring and safe lowering and raising of equipment and personnel, and has proven itself to be an indispensable tool for underground sewer, water, gas, and utility vault access.

The MiniWeigher Plus features full function push button controls for tare, choice of units (lbs, kg, kN and tonnes), peak hold, preset tare, audible set-point alarm and an overload counter.

Straightpoint's advanced microprocessor based electronics provide the MiniWeigher Plus with high speed read rates (500/sec), extreme resistance to industrial level noise and unprecedented stability. This high stability allows 5,000 + divisions and the highest standard resolution of any compact digital crane scale on the market today. The unit also features a RS-485 serial output providing added functionality and versatility.

In all, the lightweight design, corrosion resistant finish, advanced electronics and full feature display have made the MiniWeigher Plus crane scale the only choice when looking for a compact and lightweight light capacity crane scale.

Features and benefits:

- Large LCD Display
- High Accuracy
- Selectable Units
- High Resolution
- Compact Size
- Tare
- Preset Tare
- Lightweight
- Overload Counter
- Audible Set Point Alarm
- RS-485 Serial Output
- Corrosion Resistant Finish

metric specifications

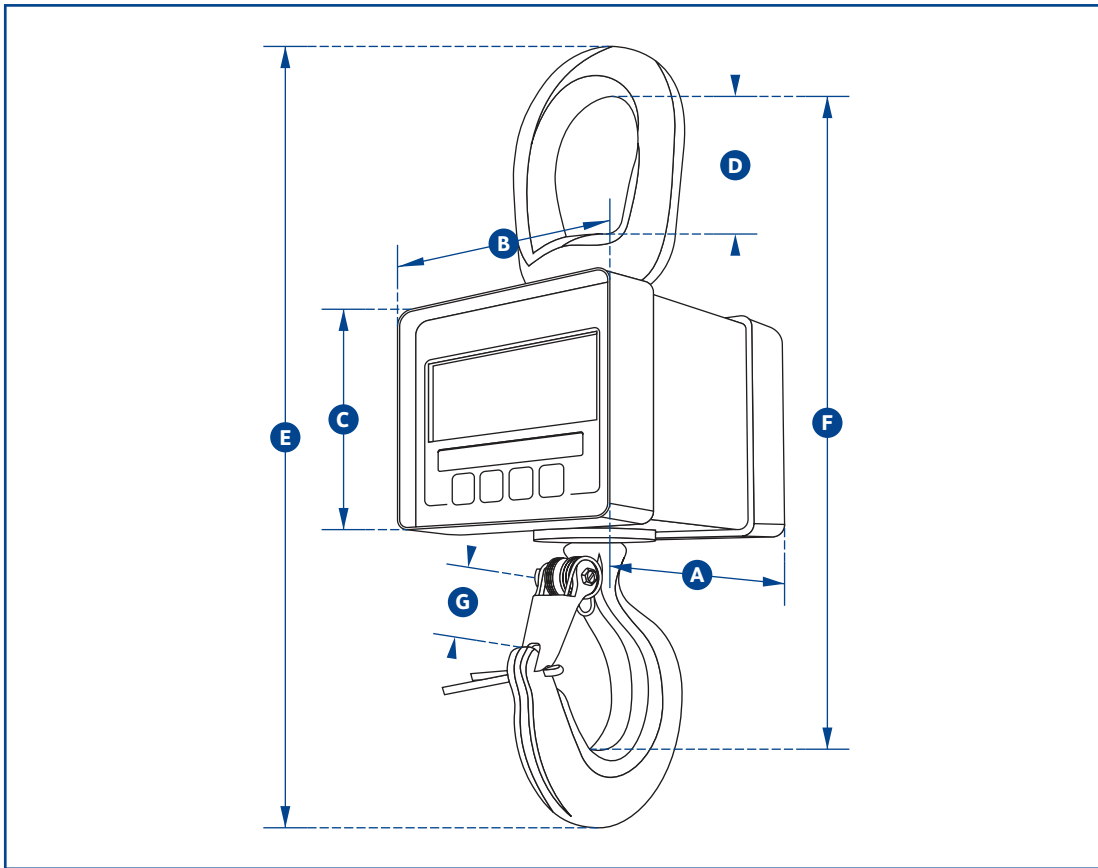

miniweigher plus

Part Number	MWP100KG	MWP250KG	MWP500KG	MWP1T	MWP2T	MWP5T
Capacity	100kg	250kg	500kg	1000kg	2te	5te
Resolution	0.05kg	0.1kg	0.2kg	0.5kg	0.001te	0.001te
Units	t, kg, kN and lbs					
Weight	1.5kg	1.5kg	1.5kg	1.5kg	3.1kg	8.7kg
Safety Factor	10:1	5:1	5:1	5:1	5:1	5:1
Battery Type	9v PP3					
Battery Life	80 hours continuous					
Operating Temp	-10°C to +50°C					
Accuracy	±0.3% of applied load					
Display Type	6 digit 25mm LCD					
Protection	IP65					
Dimension A	82	82	82	82	117	136
Dimension B	113	113	113	113	112	112
Dimension C	81	81	81	81	92	92
Dimension D	50	50	50	50	64	98
Dimension E	240	240	240	240	320	444
Dimension F	208	208	208	208	271	365
Dimension G	22	22	22	22	28	42